

XYRON[®]**PRO** 2500

U S E R ' S G U I D E

Adhesive Application & Laminating System



The XM2500 is an economical and easy to use document finishing system. This versatile and non-electric system has been designed to laminate or apply mounting adhesive to a variety of media. The same system is capable of laminating, selectively applying adhesive or laminating and applying adhesive at the same time. With the XM2500, documents are easily laminated or can be transformed into signs, stickers or labels instantly. The machine and supplies are compatible with all types of computer-printed media including laser, inkjet, color and thermal in a wide range of material sizes and thickness.

FEATURES & FUNCTIONS

Input Side

Upper Idler Bar

Lower Idler Bar

Paddle

Used to lock document in place

Feed Tray

Used to guide and align documents into the machine

Top Cover

Remove to install/remove supplies

Crank Handle

Used to advance documents and film thru machine

Output Side

Upper Supply Roll

Cut Blade

Used to trim output as it exits the machine

Rubber Rollers

Slots for Supply Installation

Blade Bars

Lower Supply Roll

Lower Access Door

Open to install and remove supplies

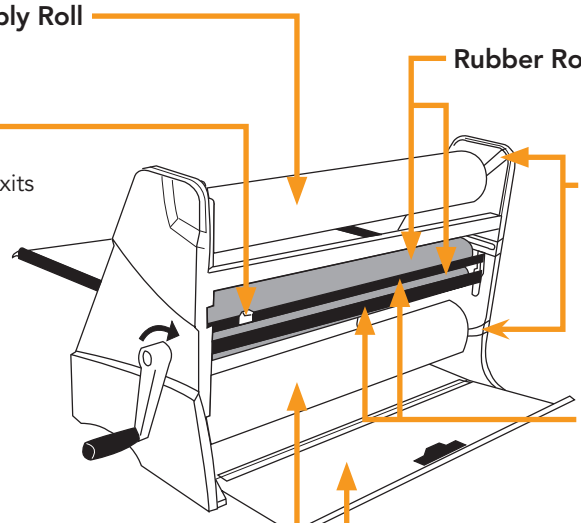
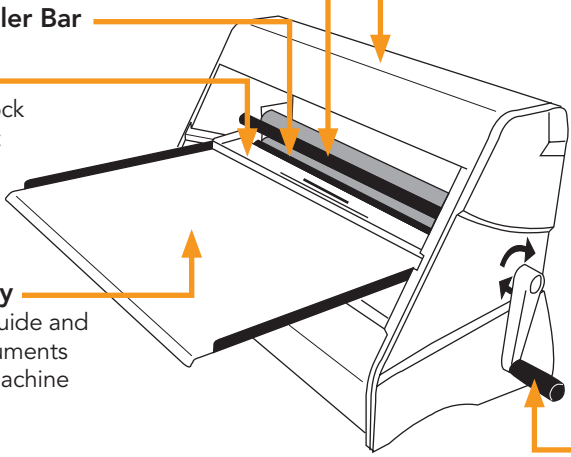

ASSEMBLY INSTRUCTIONS

Remove the XM2500, crank handle assembly and hex wrench from the packaging.

1. Place the Crank Handle assembly onto the D-shaped roller shaft with the set screw facing upward.
2. Move the handle forward on the D-shaped shaft until it stops.
3. Use the Hex wrench to secure the set screw.

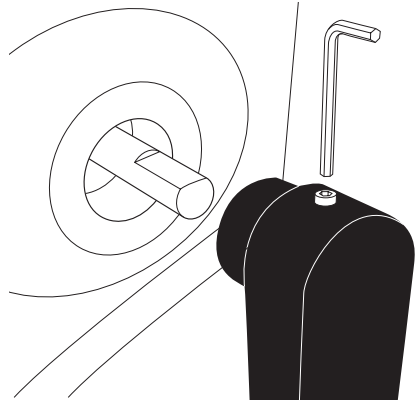

LOADING SUPPLY ROLLS

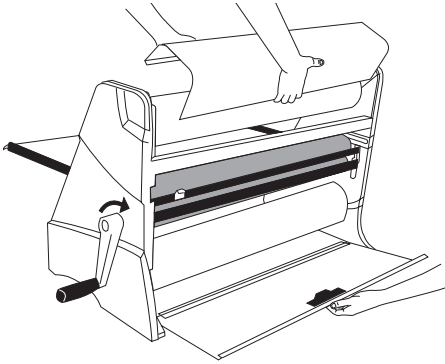

Step 1:

- Remove the top cover of the machine by lifting upward
- Grasp the handle on the lower access door; pull to open.

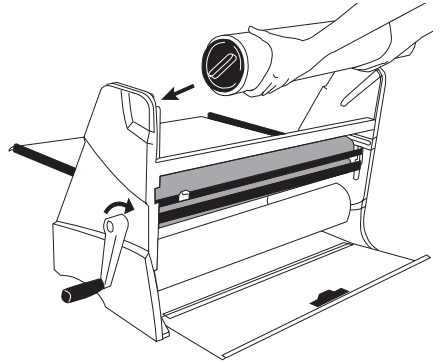

Step 2:

- Match the colored end of each supply roll with the corresponding dots on the side of the machine.
Note which roll is identified as "top" and "bottom".
- Slide the supply rolls into the grooves in the sides of the machine, making certain that the roll is inserted completely.

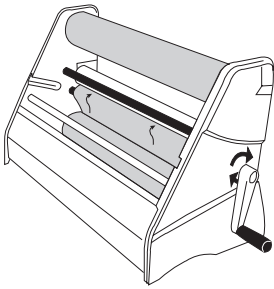

Step 3:

- On the bottom supply roll, grasp the laminated starter section by the leading edge film.
- Route over the bottom idler bar adjacent to the lower rubber roller.
- Make sure the film is inserted squarely. Rotate the handle 1/4 turn in the direction of the arrows.

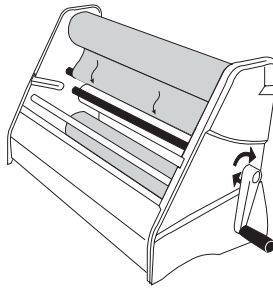

Step 4:

- Make certain the lower film is tight. If necessary, rotate the supply roll in the direction of the arrows until the film is taut.
- Grasp the film from the upper supply roll and adhere it to the film on the lower supply roll. By carefully aligning the edges, keeping the film tight and avoiding wrinkles, film waste will be minimized.

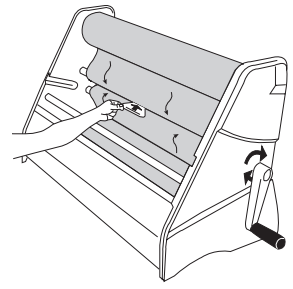

Step 5:

- Rotate the handle to pull the supplies through the machine.
- Ensure that the film exits between the blade bars.
- Just before the top film becomes tight again, insert a small piece of cardstock between the rubber rollers. This will help to minimize waste and ensure the film exits between the blade bars.

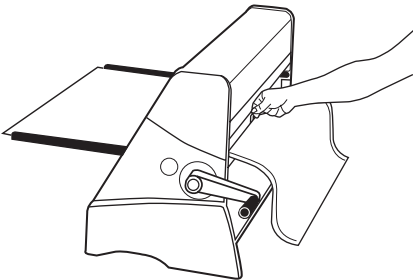

Step 6:

- Continue to crank film through the machine until it is aligned and wrinkle-free.
- Trim off excess film by pressing down on the blade holder and sliding in either direction.

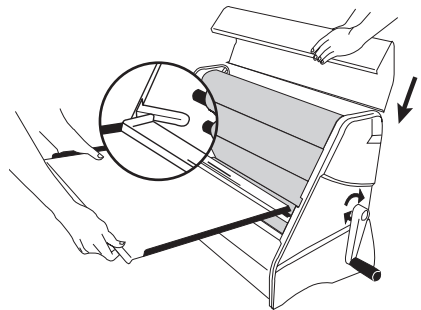

Step 7:

- Replace the top cover.
- Close the lower access door.
- Install feed tray completely by aligning the support posts in the grooves located in the sides of the machine.

When done correctly, the film layers should be aligned and wrinkle-free after 18" (45cm) of material has exited the machine.

BASIC OPERATION

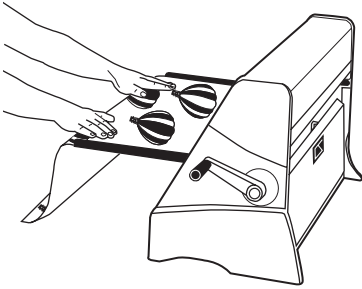

Step 1:

- Pull back on the paddle so that it is in the "up" position.
- Insert a document so the leading edge is under the paddle. The document should extend past the edge of the paddle 1-2 inches (2.5-5cm).

Note: The side of the document which is face down will have adhesive applied when using 1 Side Laminate/1 Side Mounting Adhesive.

- Align the document parallel to the edge of the feeder tray.

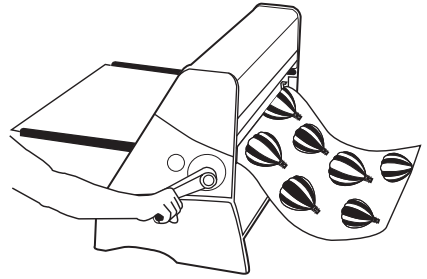

Step 2:

- Push forward on the paddle to lock the document in place.
- Ensure that the leading edge of the document is adhered down evenly. If necessary, slide your fingers across the leading edge to secure it in lace.
- Turn the handle clockwise to advance the document through the machine.

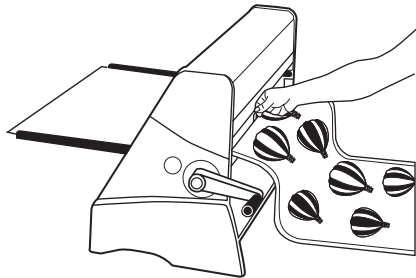

Step 3:

- Trim the document by pressing down on the blade holder and sliding it in either direction.

Note: As the document exits the machine, you may wish to trim the leading edge. This will avoid a later trimming operation.

How to remove document from adhesive

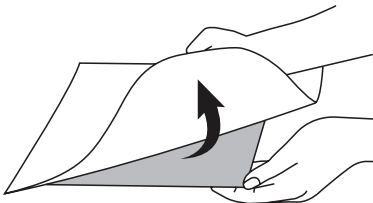

Proper Technique

- Remove the protective clear mask layer and discard.
- Always remove the liner from the media as shown.

SUPPLY ROLL REMOVAL

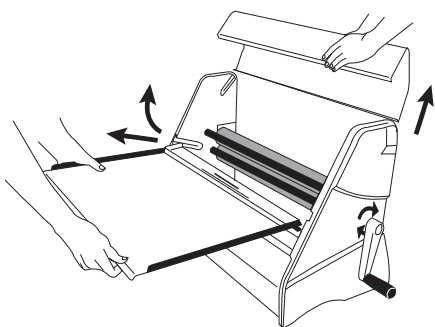

Step 1:

- Remove the top cover by lifting upward.
- Remove the feed tray by lifting and pulling away from the machine.

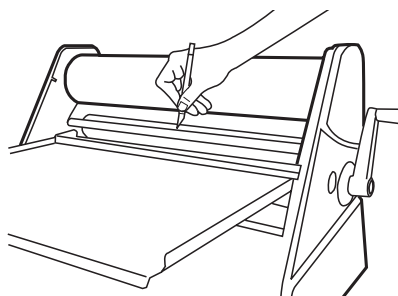

Step 2:

- Make a small hole with a knife about one inch (2.54cm) from the left edge of the film.
- Slide the knife towards the right edge of the film and stop about one inch (2.54cm) from the edge. Use caution to avoid cutting into the rubber rollers.

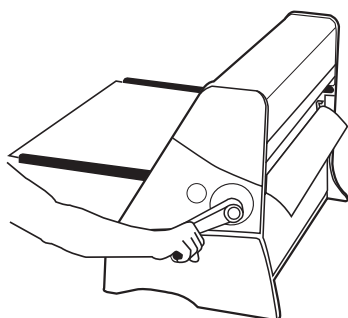

Step 3:

- Turn the handle 1/2 turn **maximum** in the direction of the arrows. This step will cause the uncut film at the edges to break, creating a laminated leader for easy installation at a later time.

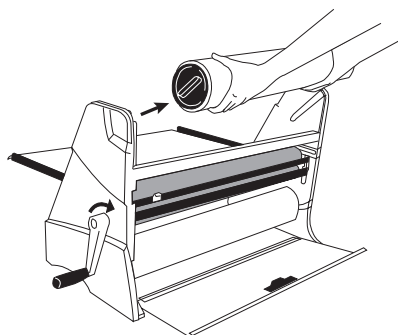

Step 4:

- Remove the supply rolls from the machine. We recommend that supplies are stored laying flat in a cool, dry place using the original packaging.

AVAILABLE SUPPLY ROLL

Product Supply Description

- Permanent High-Tack Adhesive:** Extremely aggressive adhesive instantly creates a permanent bond on most surfaces. Sets instantly and will not peel. Acid-Free.
- Permanent Standard Adhesive:** Moderately aggressive adhesive creates a permanent bond on most surfaces. Can be touched to surface, peeled back quickly, and replaced. Acid-Free.
- Repositionable Adhesive:** Allows items to be repositioned over and over. Easy removal from glass, walls, paper, and most other surfaces. Acid-Free.
- Standard Use Laminate:** High-gloss film suitable for use on a variety of substrates. Superior adhesion. Compatible with most media. Acid-Free.
- Thermal Print Sensitive Laminate:** High-gloss film suitable for use on thermal print sensitive items. Acid-Free.
- Combination – Laminate/Adhesive:** One of the laminate products described on the top surface and one of the acid-free adhesives described on the bottom surface. Acid-Free.

Part Number	Product Description	Material Length	Material Width	Laminate & Adhesive Combination Thickness (per side)	Mounting Adhesive Thickness	Adhesive PH	Mounting Adhesive Strength: 1-10 (10 High)	PAT Approved
Adhesive Application Roll Set								
AT400-300	Permanent High-Tack	300' (91.4m)	24.9" (63.4cm)	N/A	0.6mil (15.2mic)	Acid-Free	10	Yes
AT405-300	Permanent Standard	300' (91.4m)	24.9" (63.4cm)	N/A	0.6mil (15.2mic)	Acid-Free	8	Yes
AT406-170	Repositionable	170' (51.8m)	24.9" (63.4cm)	N/A	1.1mil (27.9mic)	Acid-Free	3	Yes
Lamination Roll Set								
DL403-300	2-Sided Standard Use Laminate	300' (91.4m)	25.3" (64.3cm)	2.7mil (67.5mic)	N/A	Acid-Free	N/A	Yes
DL404-300	2-Sided Thermal Print Sensitive General Use Laminate	300' (91.4m)	24.9" (63.4cm)	2.7mil (67.5mic)	N/A	Acid-Free	N/A	Yes
Combination One Side Laminate / One Side Adhesive Application Roll Set								
LAT405-300	Standard Use Laminate/ High-Tack Adhesive	300' (91.4m)	25.3" (64.3cm)	2.7mil (67.5mic)	0.6mil (15.2mic)	Acid-Free	10	Yes
LAT409-170	Standard Use Laminate/ Repositionable Adhesive	170' (51.8m)	25.3" (64.3cm)	2.7mil (67.5mic)	0.6mil (15.2mic)	Acid-Free	3	Yes

MAINTENANCE, SAFEGUARDS & TIPS

When properly used, the XM2500 is relatively maintenance-free. Listed below are safeguards and tips that will produce better results.

Importance of a clean document:

For best results when laminating, it is highly recommended that the document be cleaned with a soft, lint-free cloth immediately prior to lamination. Small dust or lint particles may cause the laminate to “tent”, producing an appearance similar to a small air bubble.

Cut blade replacement and cleaning:

The cut blade may accumulate adhesive over time. Cleaning the blade must be done with great care to avoid personal injury. To remove the blade, remove upper cut bar assembly and gently tap or wiggle a plastic end piece off. Carefully slide the orange blade holder off cut bar. Replace or clean with light solvent such as isopropyl alcohol. Carefully slide on new or cleaned blade holder and gently tap the plastic end piece on and replace cut bar assembly.

Use after storage:

For applications where the appearance of your document is critical, it is highly recommended that the XM2500 be used and stored in a clean, dust-free environment. Airborne dust particles and lint will tend to adhere to the bare adhesive inside the supply roll. If the machine has not been used for several days or was subject to a dusty environment, it is recommended that 4” (10cm) of material be advanced and discarded before inserting your document. It is also recommended that the feed tray is cleaned with a lint-free cloth.

Cleaning adhesive from the nip rollers:

The nip rollers are designed to be self-cleaning under normal use. If adhesive does accumulate, it can normally be removed by first removing the supply films from between the nip rollers and advancing a scrap piece of regular bond paper through the machine. The bare adhesive will tend to attach to the paper. If this method of cleaning does not work, the nip rollers can be cleaned with a light solvent such as isopropyl alcohol. Take care not to scratch, cut or chip the rollers. For best results when laminating, it is critical that the lower idler bar be kept clean of adhesive buildup.

Product Specifications

Footprint	18.5” x 28.125” x 15” (47cm x 71.4cm x 38.1cm)
Weight/Packed Weight	90lbs (40.8kg) / 105lbs (47.6kg)
Document Thickness (max.)	0.10” (2.5mm) Up to 3/16” foam core with tray removed
Finished Document Width (max.)	25” (63.5cm)
Power Requirements	None
Cutter	Removable, replaceable cutter

TROUBLESHOOTING

Symptom	Cause	Solution
Long documents (such as banners) are not aligned with film layers after laminating.	Feed Tray not installed correctly or supply roll not seated at base of groove in side plate(s).	Verify tray is completely installed such that it is approximately level and square. Also, verify supply rolls are completely seated at base of grooves in side plate(s).
Cut Blade does not slide smoothly.	Upper Blade Bar sticking in side plate groove or blade sticking on Blade Bar.	Apply silicon lubricant to all surfaces of top blade bar.
Film does not exit machine between Upper and Lower Blade Bars.	Material is curled or adhesive has been transferred to the Nip Roller causing the film to stick.	Reposition material between upper cut bar and lower guide. Clean adhesive from nip rollers if necessary.
Cut Blade does not cut well.	Blade has accumulated adhesive buildup or is dull.	Clean adhesive buildup from blade using isopropyl alcohol. Replace blade if necessary.
Thin and/or wide documents tend to wrinkle during lamination.	Paddle not operated correctly, or tray and/or paddle are not flat.	Ensure paddle is pushed forward completely after document is loaded and aligned. Ensure document is extended approximately 1-2" (16mm) past edge of paddle before pushing paddle forward. Also, check that the leading edge of document is evenly adhered ("locked") to lower supply film by temporarily pulling paddle back after it has been completely pushed forward. Check paddle and tray for flatness.
Document difficult to load.	Paddle not pulled back to load position or has adhesive buildup on underside.	Prior to loading document, pull paddle back to "load" position. Ensure underside of paddle is clear of any obstruction or adhesive buildup.
Film wrinkles don't go away as crank is turned clockwise.	Upper and/or lower supply roll(s) are not firmly seated in grooves within side plate(s).	Verify supply rolls are firmly seated at base of grooves in side plates.
Film does not lay flat, curls and/or wrinkles.	Adhesive buildup on lower idler bar.	Clean adhesive buildup from idler roller using isopropyl alcohol.

Warranty Information

Xyron, Inc. warrants that the XM2500 is free from defects in material and workmanship for a period of one (1) year from the date of purchase. Xyron, Inc. will repair or replace a defective product or part without charge, with proof of purchase. If the product is damaged by neglect or misuse, the warranty is null and void.

To register your product online, please go to www.xyronpro.com and click on the product registration tab.

*If you purchased this product outside the United States, Xyron will warrant this product in accordance with the purchasing country's laws.**

**Excludes Australia

Customer Service

We want you to be happy with your purchase of a Xyron product. If for any reason you have a problem or a question, please contact Xyron Customer Service toll-free at 1-800-793-3523 or 1-480-443-9419 for help. You can also e-mail us at: customerservice@xyron.com

For customer service outside of the U.S.:

Australia: 61 2 8899 8500; australiacustomers@esselte.com

New Zealand: 64 9 272 1600; nzcustomers@esselte.com

Europe: 44 845 67801801

Asia: 813 5719 6450

©2011 Xyron, Inc.
8465 N. 90th St. Suite 6
Pima Center
Scottsdale, AZ 85258

1259_RevC

 **XYRON**[®]

An  **Esselte**[®] Company

Visit www.xyronpro.com for more information.